



viper-k3

viper-k3 is a Logue multi-engine oscillator which provides high quality emulation of the waveforms from the classic Kawai K3 keyboard and K3m module.

The main features are:

- 31 waveforms modelled on the K3's digital oscillator
- high quality, alias-free re-synthesis engine with 16 bit sample resolution
- dual oscillators plus white noise
- single-stage pitch envelope providing auto-bend
- slew-rate limiter for glitch-free LFO shape modulation
- CPU load control (NTS1 only)

viper-k3 uses a specialised synthesis engine with models that reconstruct the original waveforms in real time. The engine is fully anti-aliased and generates waveforms with 16 bit resolution, giving the potential for higher fidelity than the original instrument's 8 bit output.

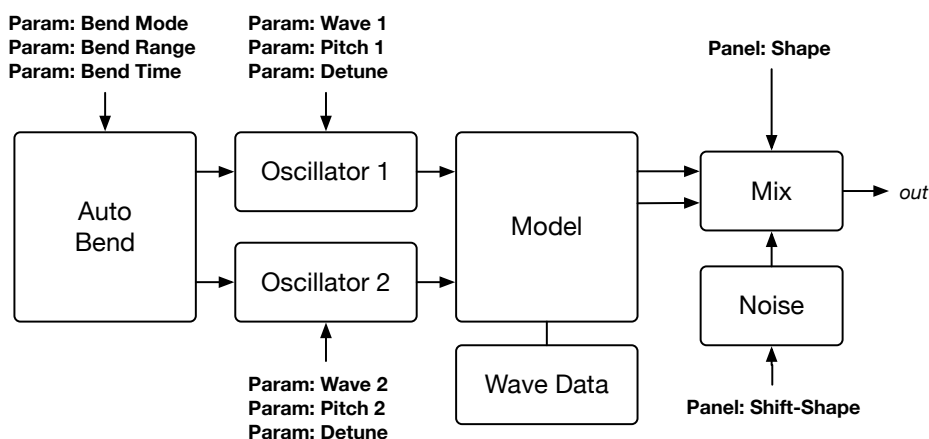

viper-k3 also provides a single-stage pitch envelope that emulates the an auto-bend function. This can be set to create subtly shifting detune effects or dramatic frequency sweeps.

On the NTS1, a CPU limiter is available. The NTS1's processor is shared by both oscillator and effects units, and too much CPU load can cause audio breakup. By default, **viper-k3** on the NTS1 has a conservative CPU load, but this can be manually increased to give higher audio quality if heavy effects processing is not used.

Parameters and Controls – Prologue and Minilogue XD

Use the *Shape* control to set the mix between the two oscillators. The minimum setting corresponds to oscillator 1 only, and the maximum to oscillator 2.

Use *Shift-Shape* to mix between the oscillators and the white noise generator.

The programmable parameters are:

Parameter	Range	Function
Wave 1	1 – 16	Sets the waveform for oscillator 1.
Wave 2	1 – 16	Sets the waveform for oscillator 2.
Pitch 1	-100 – 100	Sets the pitch of oscillator 1, over a range from 1 octave below to 1 octave above. The adjustment is non-linear, providing finer control over detuned around zero. Be aware that the Logue software may default the pitch value to -100, resulting in sounds an octave lower than might be expected.
Pitch 1	-100 – 100	Sets the pitch of oscillator 1, over a range from 1 octave below to 1 octave above. The adjustment is non-linear, providing finer control over detuned around zero. Be aware that the Logue software may default the pitch value to -100, resulting in sounds an octave lower than might be expected.
Bend Time	0 – 100	Sets the duration of the bend effect. A value of zero disables auto-bend. Values from 1 to 100 specify the bend time, ranging from approximately 10ms to 10s.
Bend Range	-100 – 100	Sets the range of the bend effect. A value of zero disables auto-bend. A value of -100 gives a rising auto-bend of one octave. A value of +100 gives a falling auto-bend of one octave.

Parameters and Controls – NTS1

Use knob A (*SHPE*) to set the mix between the two oscillators. The minimum setting corresponds to oscillator 1 only, and the maximum to oscillator 2.

Use knob B (*Alt*) with shift to mix between the oscillators and the white noise generator.

The programmable parameters are:

Parameter	Range	Function
Wav1	1 – 16	Sets the waveform for oscillator 1.
Wav2	1 – 16	Sets the waveform for oscillator 2.
Pit1	-100 – 100	<p>Sets the pitch of oscillator 1, over a range from 1 octave below to 1 octave above. The adjustment is non-linear, providing finer control over detuned around zero.</p> <p>Be aware that the Logue software may default the pitch value to -100, resulting in sounds an octave lower than might be expected.</p>
BTim	0 – 100	<p>Sets the duration of the bend effect.</p> <p>A value of zero disables auto-bend.</p> <p>Values from 1 to 100 specify the bend time, ranging from approximately 10ms to 10s.</p>
BRan	-100 – 100	<p>Sets the range of the bend effect.</p> <p>A value of zero disables auto-bend.</p> <p>A value of -100 gives a rising auto-bend of one octave. A value of +100 gives a falling auto-bend of one octave.</p>
CPU	1 – 16	<p>Sets the CPU allocation used by the unit.</p> <p>A value of 1 specifies the lowest CPU usage. A value of 16 specifies the highest CPU usage.</p> <p>Allowing a higher CPU usage may improve the rendering quality of some waveforms, most noticeably at lower frequencies.</p> <p>However, if several effects are used at the same time as <i>viper</i>, an overload may occur resulting in audio breakup. If this happens, reduce the number of concurrent effects units or reduce the CPU allocation given to <i>viper</i>.</p>

Waveform List

Wave	Emulated K3 Waveform
1	Grand Piano I
2	Bell
3	Strings
4	E. Bass
5	Oboe
6	E. Piano I
7	Organ
8	Brass I
9	Digital Bell
10	Slap Bass
11	Plucked String
12	Classic Guitar
13	Hammered Tine
14	Metalic Wave
15	Vox Humana
16	Sharp Wave
17	Digital Harmonics
18	Pipe Organ
19	Wood Bass
20	Resonant Strings
21	E. Piano II
22	Jazz Organ
23	Glocken
24	Oriental Bell
25	Harpsichord
26	Trumpet
27	Sax
28	Grand Piano II
29	Square
30	Sawtooth
31	Sine

Downloading and Feedback

Information and updates can be found at <https://tsoniq.com/software/korg/viper>.

You can send feedback by email to logue@tsoniq.com, or leave a comment on the download page.

Installation

viper-k3 is supplied as a zip archive containing three units:

viper-k3.prlgunit	Prologue 8 and 16
viper-k3.mnlgxdunit	Minilogue XD
viper-k3.ntkdigunit	NTS-1

Use the appropriate Librarian application (available from <https://korg.com>) to send the appropriate unit to the synthesiser.

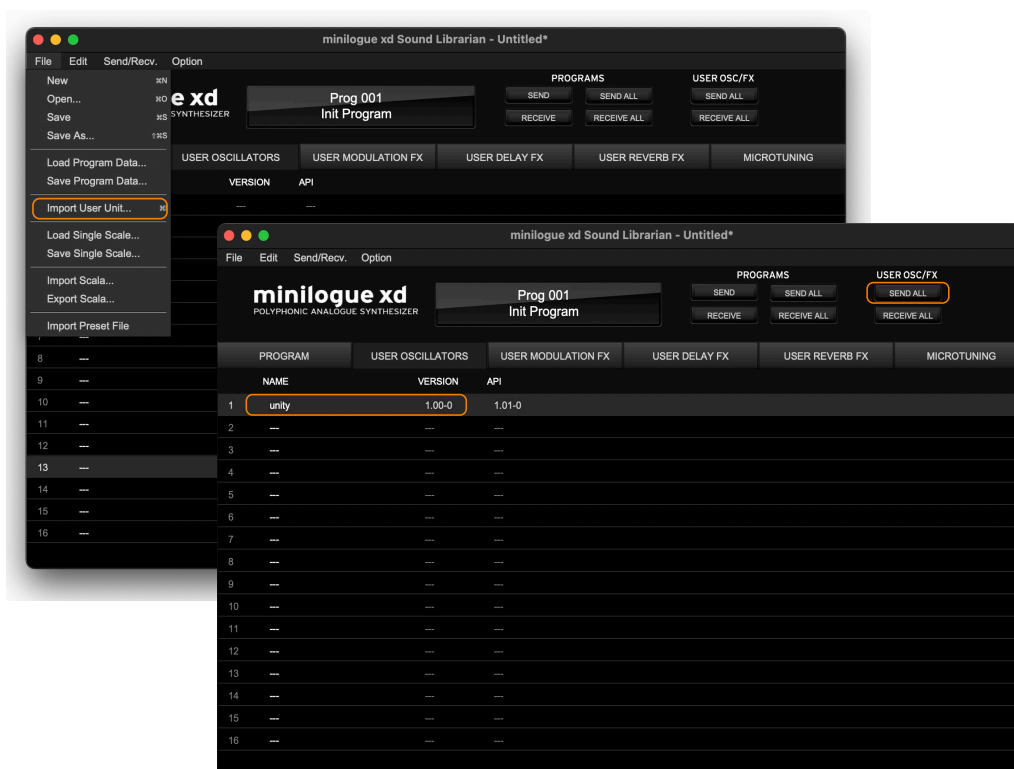

Requirements

viper requires a Korg NTS-1, Minilogue XD, Prologue 8 or Prologue 16.

Installation requires the use of a PC or macOS computer and the Korg Librarian software appropriate for the synthesiser.

Copyright, Warranty and Liabilities

The copyright to **viper-k3** is held by tsoniq. Please support independent developers by not stealing this software.

No warranty is implied. Any liability resulting from the use of this software is limited to the purchase price.

Release History

Version	Release Date	Changes
1.0	11-Dec-2023	Initial release.